

# Ultraviolet Air Treatment Systems

## 24 Volt UV Air Purifier with AirBRIGHT™ Odor Absorption



Honeywell's UV Air Purifier with AirBRIGHT Odor Absorption is installed in the ductwork of your central air system and is designed to help reduce airborne odors, toxic chemical vapors, germs and mold in your home. Through the use of Advanced Photocatalytic Oxidation (PCO) technology, Honeywell's UV Air Purifier combines germicidal UV light and activated carbon cells to reduce volatile organic compounds (VOC's) in the air.

- Lamp is Always On
- Replace Lamp Annually
- AirBRIGHT Odor Absorber never needs replacing
- SnapLamp™ features replacement lamp handle with detachable replacement lamp.
- Universal Installation with a single product
  - UV Only
  - UV + Odor Removal
  - Internal Mount
  - External Mount

Indoor  
Air Quality

**Input:** 18-32  
**Voltage :** 0.8A  
**Application:** Whole Home Air Purification

**Mounting:** Universal - External or Internal (Magnets)  
**Color:** Dark Empire Grey

| Product Number | Description                                    | Comments   |
|----------------|--|--|
| UV2400U1000/U  | UV Air Purifier                                | Surface Treatment  |
| UV2400U5000/U  | UV Air Purifier with AirBRIGHT Odor Absorption | Surface Treatment Plus VOC Reduction/Odor Absorption       |
| UV2400XPCO1/U  | AirBRIGHT Odor Assembly                        | Odor Assembly Only - Requires UV Air Purifier              |
| UV2400XLAM1/U  | Replacement Lamp                               | Replace every 12 Months                                    |
| UV2400XBAL1/U  | Replacement Ballast                            | —  |
| UV2400XDBA1/U  | Duct Board Adapter                             | Securely fasten UV Air Purifier to Duct Board Applications |

### Dimensions in inches (millimeters)

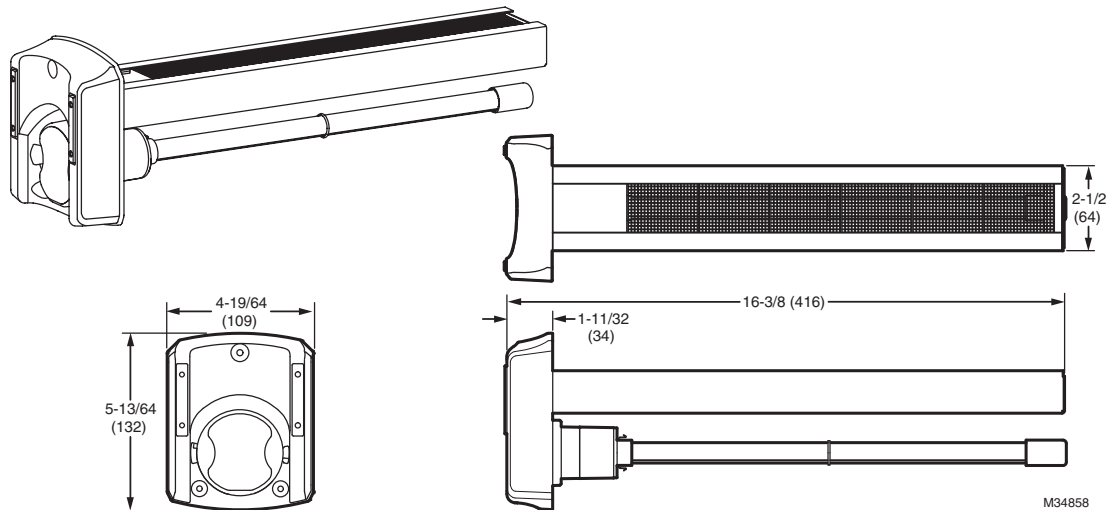

### Internal and external (universal) mounting for the UV air purifier

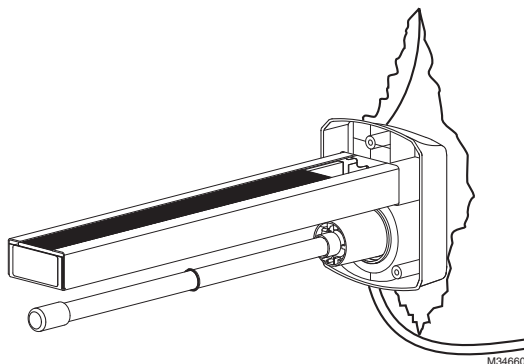

Internal Mount

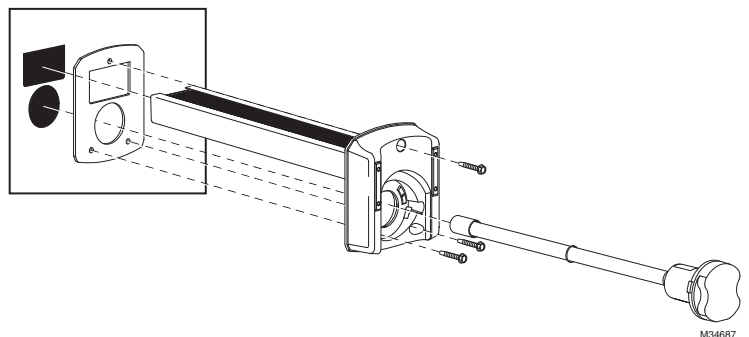

External Mount